

SOLUTIONS

Separation Solutions for Centrifuge Machines

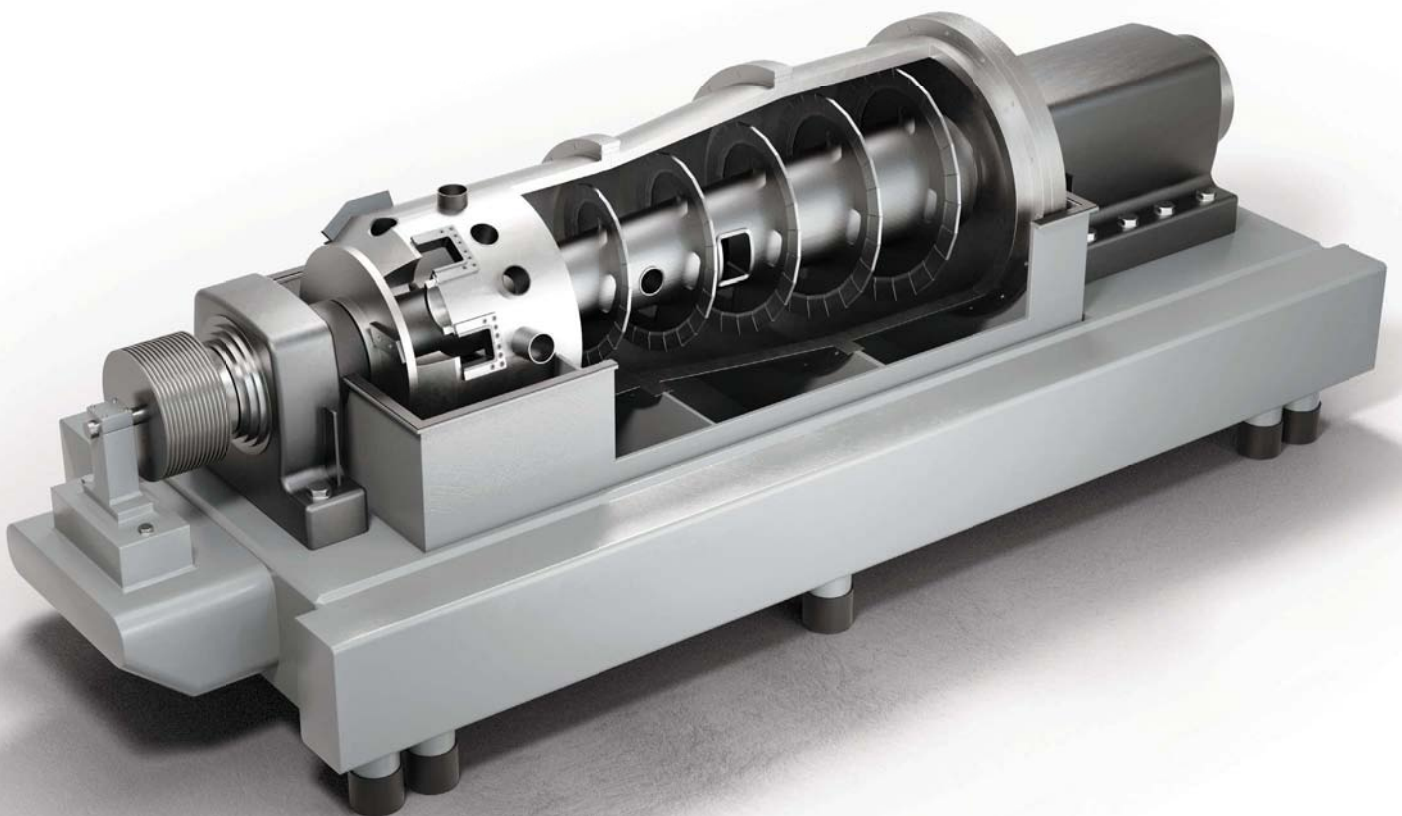

Wear Solutions for Decanter Centrifuge Machines

With a thorough understanding of our customers' process and application challenges, we proactively address wear, heat, and corrosion problems to deliver productivity, reliability, and extended life to Original Equipment Manufacturers (OEM) and rebuilders of centrifugal separation equipment.

Our drive for success, enabled through our advanced materials sciences, application knowledge, and design expertise, results in a broad portfolio of innovative, custom, wear-resistant solutions.

Carbide Wear Components

We supply standard and make-to-print wear components from tungsten carbide based material. These include sintered carbide blanks and assembled/brazed ready-to-use components.

We also perform analytical services to help you develop or improve the service life of your equipment.



Decanter Centrifuge Tiles

With our new centrifuge tile, we have developed a product that brings OEM quality and reliability to the centrifuge rebuilder as a standard offering to the market.



Tungsten Carbide Materials

Kennametal was founded on an innovative formula of tungsten carbide. Today, carbide is still the primary material for our tools and wear products.



CONTACT US

k-mdsn.inside-sales@kennametal.com | +1 800 221 4273 | kennametal.com/centrifuge

Solid & Screen Bowl Decanter Centrifuge Components

- Scroll Flight Tiles (brazed carbide/steel assembly)
- Feed and Discharge Nozzles
- Scraper Bars & Plows
- Wear Tile Platelets
- Screen Bars

Other Material Solutions Available from Kennametal

- Stellite™
- Conforma Clad™
- UltraFlex™
- Hard-Facing Materials

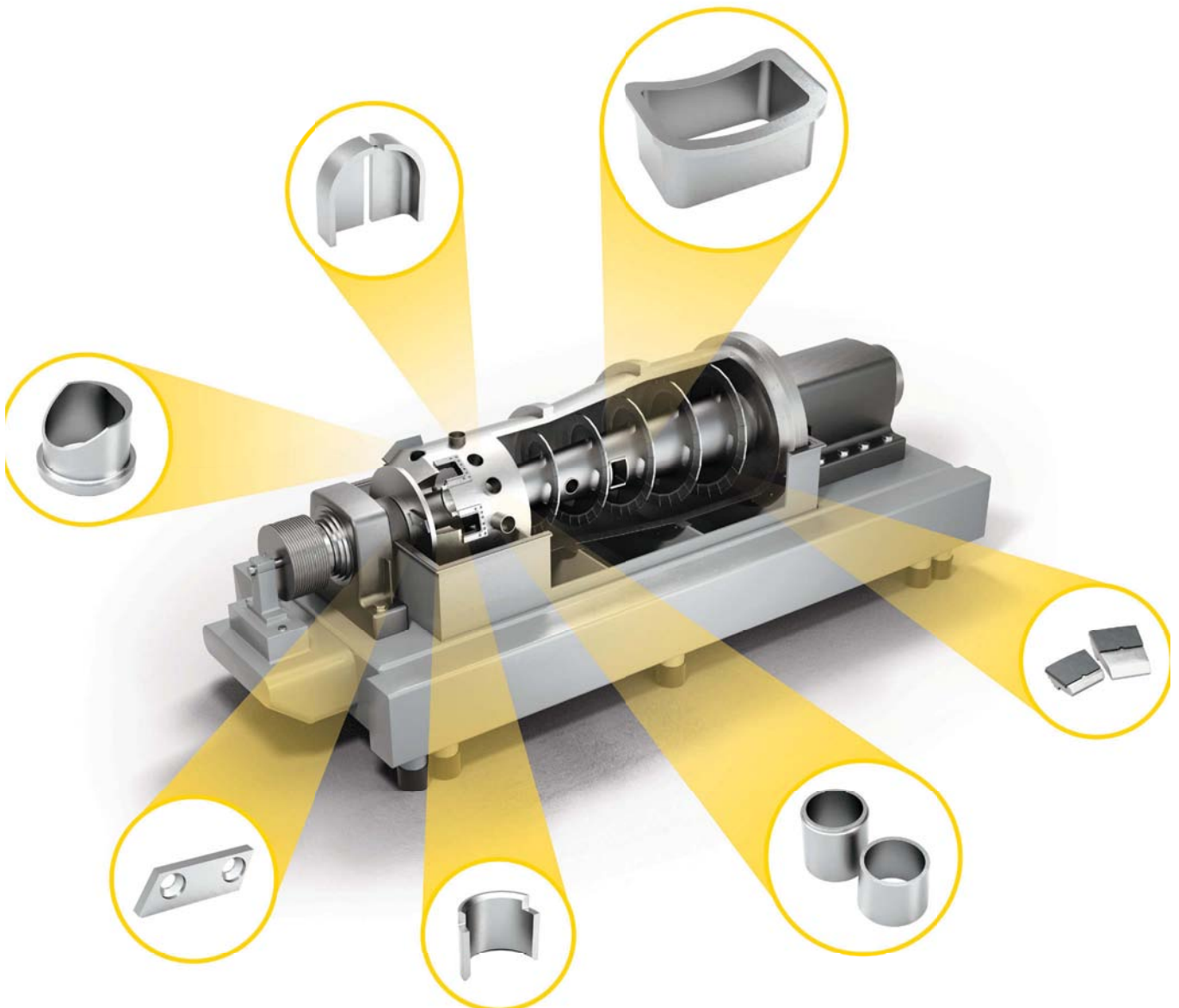

Longer Life and Increased Reliability for Decanter Centrifuge Machines

A decanter centrifuge plays a critical role in the wastewater, chemical, oil, food processing industries, and harsh environments that require continuous operation.

Corrosion and untimely wear cause premature tile loss, unbalanced rotation, and excessive vibration of the centrifuge, all resulting in unfavorable downtime.

Kennametal centrifuge tiles are engineered for high reliability and minimize these common problems in solids control and dewatering applications.

Focus Product: Centrifuge Tiles

Wear resistance of the carbide tile is always a concern, and Kennametal has that covered with our industry proven grades, but really the biggest issue we see in the market is tile delamination.

Brazing preparation is a key concern. Oils and other contaminants like surface oxidation on the carbide and steel components can prevent a good bond from forming. You can also have variability in the braze joint and quality of the bond, depending on the experience of the brazing technician.



Competitive Analysis: Scan of Braze Joint

A fluxing agent is commonly used to aid in wetting of the carbide to the steel. This may help mitigate some of the issues referenced above.

However, there are downsides. The flux is corrosive and is difficult to evacuate, which results in voids under the tile (as shown in the images below). These voids are very common, and when located at an edge, can allow the fluids in the centrifuge to enter and cause accelerated crevice corrosion, and ultimately lead to the carbide disbonding from the backing plate.

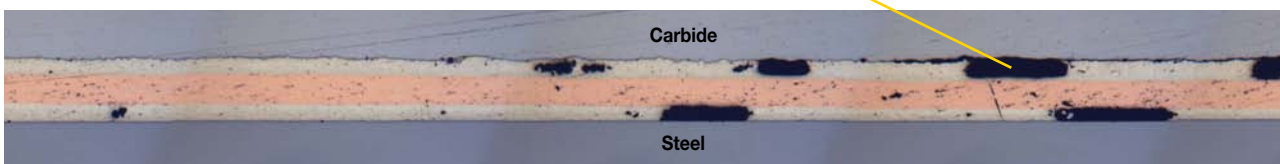
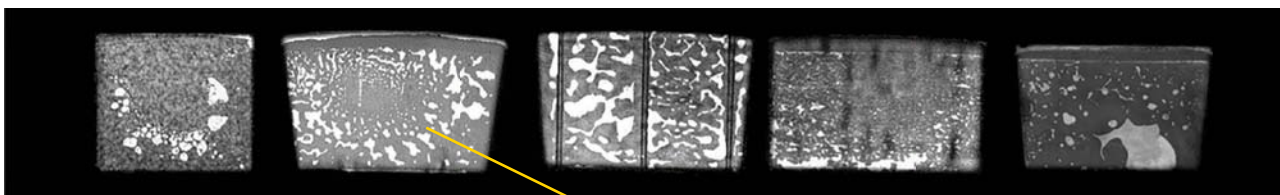

Cross section of the tile showing voids.

Kennametal KDCT Brazed Tiles — Virtually Void-Free

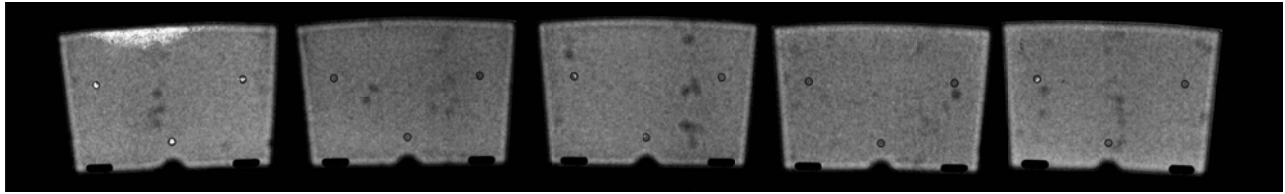

Our answer to these brazing challenges has been to apply our proven brazing technology and develop a total solution to eliminate these issues with decanter centrifuge tiles. ***This has resulted in a virtually void-free bond between carbide and steel.***

How do we achieve this?

- Multistep surface preparation with both carbide and steel.
- Proprietary braze formula that is corrosion-resistant and **does not** use flux.
- Our self-fixturing carbide mates to the steel for a consistent joint thickness and does not rely on the technician's skill to achieve.
- Best-in-class, corrosion-resistant carbide made from our own grades.

That is why we believe our tile is the most reliable tile offered to the rebuilder market today.

Why Choose Kennametal Centrifuge Tiles?

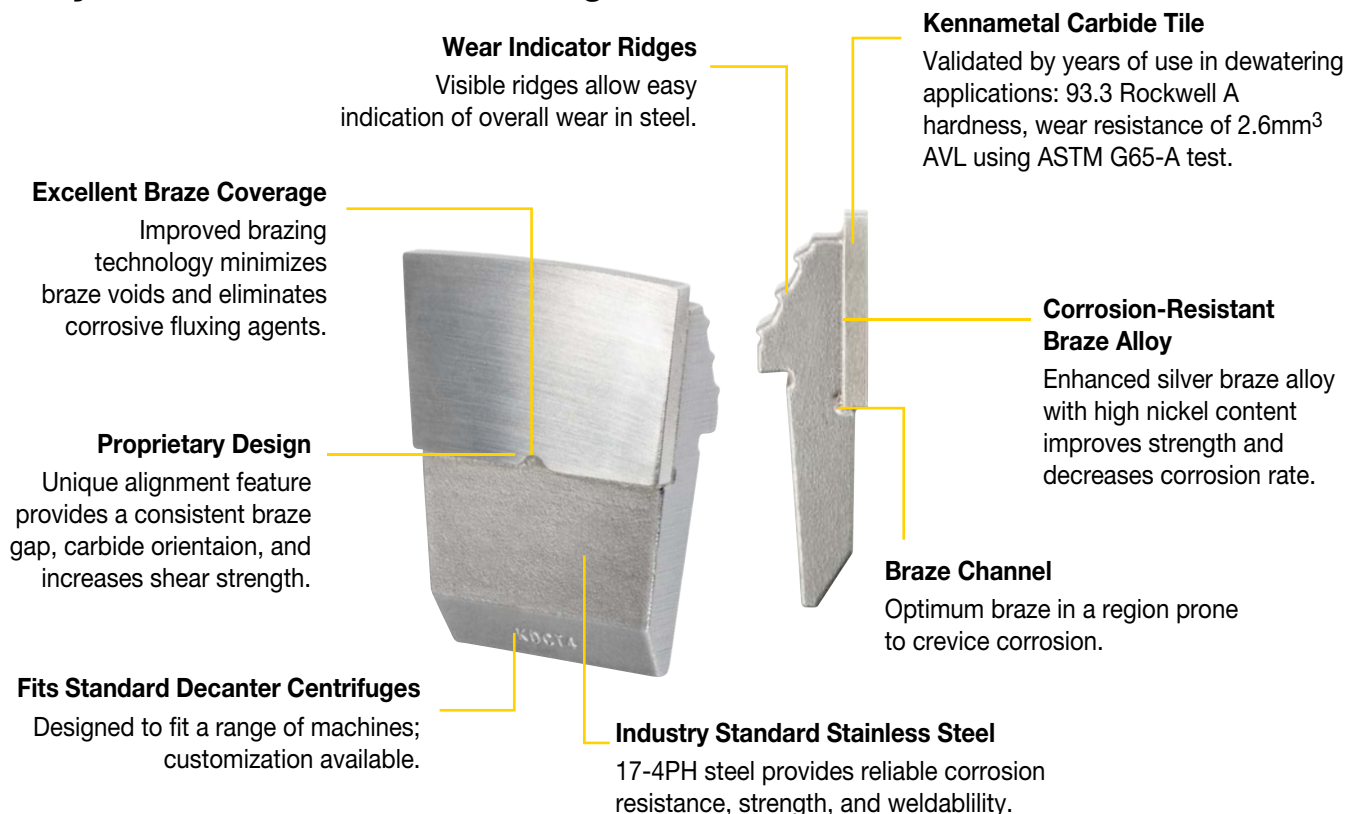

Kennametal technical resources are second to none; it's our not-so-secret weapon that has allowed us to develop one of the best centrifuge tiles on the market. Our quality assurance and validation steps include:

- Ultrasonic C-Scan of braze joint
- Microstructure evaluation of braze joint
- 100% visual inspection of external braze joint and of carbide
- ASTM G65 Procedure A – Abrasive Wear Testing
- Corrosion Testing – gravimetric and potentiostatic methods
- Salt water immersion testing
- Rockwell Hardness Testing of steel backer after brazing

Tungsten Carbide Materials



Production Process for Cemented Tungsten Carbide Products

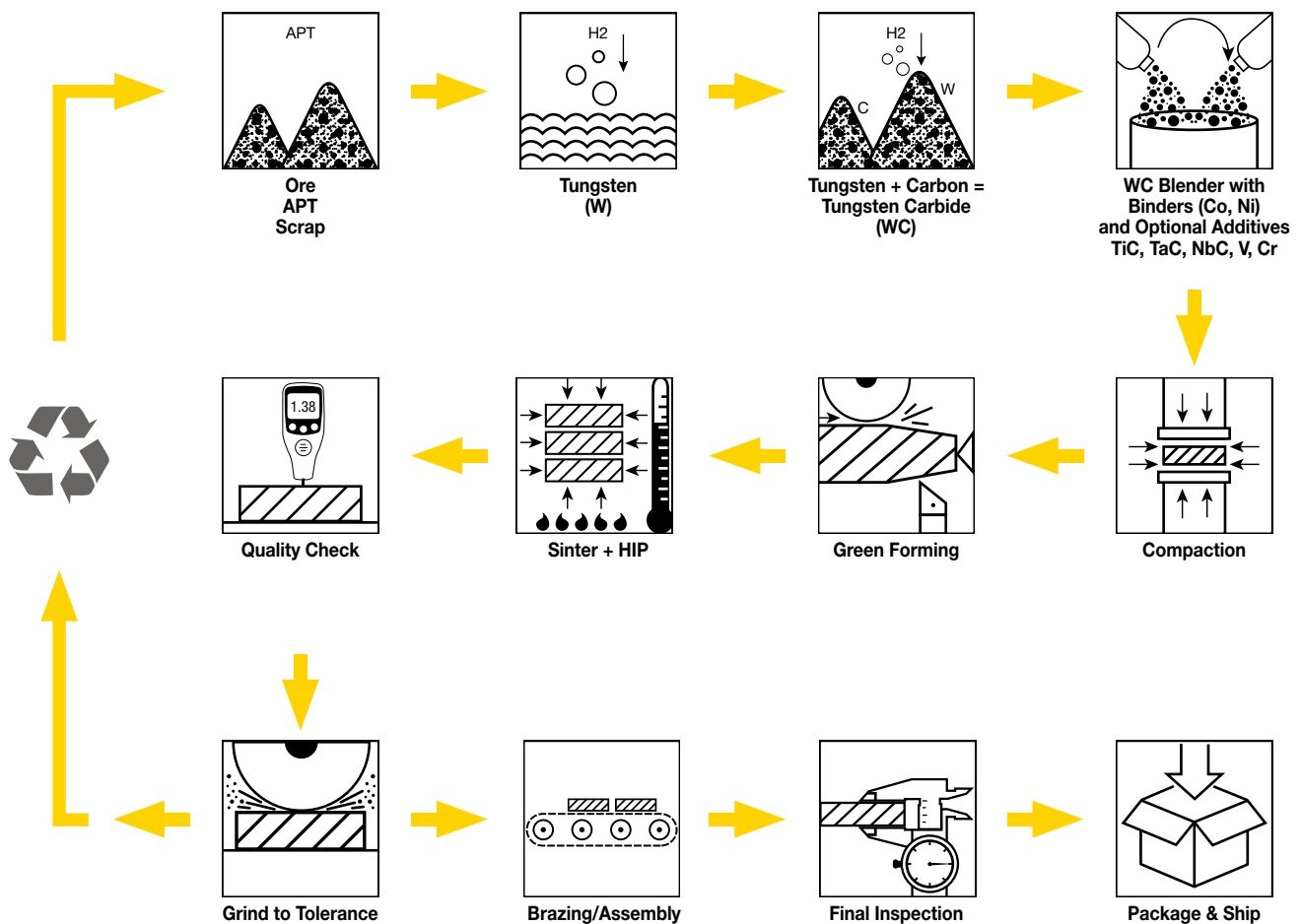

Cemented Tungsten Carbide Grades

We offer a wide variety of carbide grades, including submicron, fine, medium, and coarse-grained tungsten carbides with a mixture of binders and additives to create the right balance of hardness, toughness, abrasion, and corrosion resistance for the application.

Hardness

Hardness is determined by the percentage of binder and the grain size of the tungsten carbide particles. Generally, the more binder, the lower the hardness, and the larger the grains, the lower the hardness.

Wear Resistance

Generally, grades with more binder or coarser grains (lower hardness) will have less wear or abrasion resistance. However, there will be an increase in strength. It is always necessary to balance high hardness/high wear resistance with lower hardness/high strength. To test the abrasion or wear resistance of our carbide grades, we typically conduct a dry sand (G65) or slurry tests (B611).

Strength

The amount of binder and the variation in grain size will also affect the impact strength (a shock load) and the fracture toughness (a measure of crack initiation and crack propagation). More binder and/or coarser grains will generally increase the impact strength and the fracture toughness. With submicron grained grades, impact strength and the fracture toughness decrease when compared to coarser grained grades of equal cobalt content; however hardness increases.

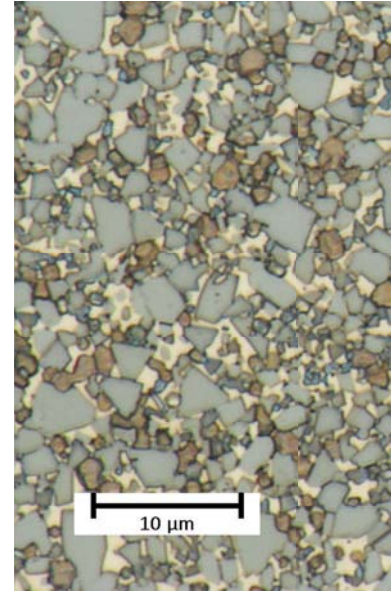

Example of Cemented Carbide with Medium-Coarse Grains

Cemented Tungsten Carbide Grades

Grade Name	Binder	Binder (wt %)	Hardness		Grain Family
			HRA	HV30	
KFS33	Co	6	93.0	1800	Submicron
KFS64	Co	10	91.8	1590	Submicron
KFM65	Co	11	89.7	1310	Medium
HARC	Co-Cr	6.9	93.3	1850	Fine
K701*	Co-Cr	10	92.4	1680	Fine
CNC68	Co-Ni-Cr	6.5	93.4	2000	Submicron
CNC10	Co-Ni-Cr	8.5	90.5	1410	Fine
KR855	Co-Ni-Cr	10	91.8	1580	Submicron
KR466	Co-Ni-Cr	12	90.0	1355	Fine-Medium
CN13S	Co-Ni-Cr	12.5	88.7	1220	Coarse
KR887	Co-Ni-Cr	15	90.2	1370	Submicron
HAN6	Ni	6	90.5	1410	Medium
GTD	Ni-Cr	9.2	91.6	1550	Fine
HAN10	Ni	10	90.0	1340	Fine

*K701 is not able to be brazed.

Additional cemented tungsten carbide materials available, as well as ROCTEC™ and Stellite™ options.

CONTACT US

k-mdsn.inside-sales@kennametal.com | +1 800 221 4273 | kennametal.com/centrifuge



WORLD HEADQUARTERS

Kennametal Inc.

1600 Technology Way
Latrobe, PA 15650 USA
Tel: 1 800 446 7738
ftmill.service@kennametal.com

EUROPEAN HEADQUARTERS

Kennametal Europe GmbH

Rheingoldstrasse 50
CH 8212 Neuhausen am Rheinfall
Switzerland
Tel: +41 52 6750 100
neuhausen.info@kennametal.com

ASIA-PACIFIC HEADQUARTERS

Kennametal Singapore Pte. Ltd.

3A International Business Park
Unit #01-02/03/05, ICON@IBP
Singapore 609935
Tel: +65 6265 9222
k-sg.sales@kennametal.com

INDIA HEADQUARTERS

Kennametal India Limited

CIN: L27109KA1964PLC001546
8/9th Mile, Tumkur Road
Bangalore - 560 073
Tel: +91 080 22198444 or +91 080 43281444
bangalore.information@kennametal.com

kennametal.com